

It is of vital importance, before attempting to operate your engine, to read the general 'SAFETY INSTRUCTIONS AND WARNINGS' in the following section and to strictly adhere to the advice contained therein.

- Also, please study the entire contents of this instruction manual, so as to familiarize yourself with the controls and other features of the engine.

SAFETY INSTRUCTIONS AND WARNINGS ABOUT YOUR O.S. ENGINE

Remember that your engine is not a "toy", but a highly efficient internal-combustion machine whose power is capable of harming you, or others, if it is misused or abused. As owner, you, alone, are responsible for the safe operation of your engine, so act with discretion and care at all times. If at some future date, your O.S. engine is acquired by another person, we would respectfully request that these instructions are also passed on to its new owner.

- The advice which follows is grouped under two headings according to the degree of damage or danger which might arise through misuse or neglect.

⚠ WARNINGS

These cover events which might involve serious (in extreme circumstances, even fatal) injury.

⚠ NOTES

These cover the many other possibilities, generally less obvious sources of danger, but which, under certain circumstances, may also cause damage or injury.

⚠ WARNINGS

Model engine fuel is poisonous. Do not allow it to come into contact with the eyes or mouth. Always store it in a clearly marked container and out of the reach of children.

Model engine fuel is also highly flammable. Keep it away from open flame, excessive heat, sources of sparks, or anything else which might ignite it. Do not smoke or allow anyone else to smoke, near to it.

Model engines generate considerable heat. Do not touch any part of your engine until it has cooled. Contact with the muffler (silencer), cylinder head or exhaust header pipe, in particular, may result in a serious burn.

Never operate your engine in an enclosed space. Model engines, like automobile engines, exhaust deadly carbon-monoxide. Run your engine only in an open area.

⚠ NOTES

- This engine is intended for model cars. Do not attempt to use it for any other purpose.
- Mount the engine in your model securely, following the manufacturers' recommendations, using appropriate screws and locknuts.

- Install an effective silencer (muffler). Frequent close exposure to a noisy exhaust (especially in the case of the more powerful highspeed engines) may eventually impair your hearing and such noise is also likely to cause annoyance to others over a wide area.
- The wearing of safety glasses is also strongly recommended.
- Take care that the glowplug clip or battery leads do not come into contact with rotating parts. Also check that the linkage to the throttle arm is secure.
- For their safety, keep all onlookers (especially small children) well back (at least 20 feet or 6 meters) when preparing your model for running.
- Before starting the engine, always check the tightness of all the screws and nuts especially those of joint and movable parts such as throttle arm. Missing retightening the loose screws and nuts often causes the parts breakage that is capable of harming you.

- To stop the engine, fully retard the throttle stick and trim lever on the trans-mitter, or, in an emergency, cut off the fuel supply by pinching the fuel delivery line from the tank.
- Warning! Immediately after a glowplug-ignition engine has been run and is still warm, conditions sometimes exist whereby it is just possible for the engine to abruptly restart if it is rotated over compression WITHOUT the glowplug battery being reconnected.

■ BASIC ENGINE PARTS

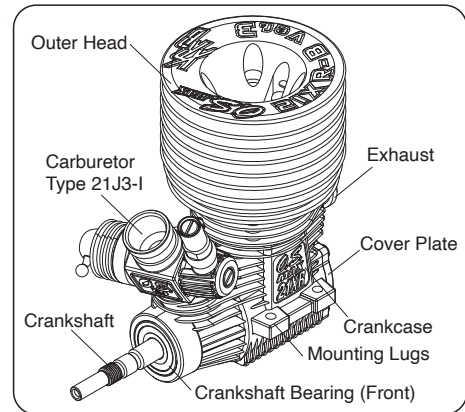

■ CARBURETOR CONTROLS - STANDARD POSITIONS (POSITIONS WHEN THE ENGINE LEAVES THE FACTORY)

Four adjustable controls are provided on this carburetor.

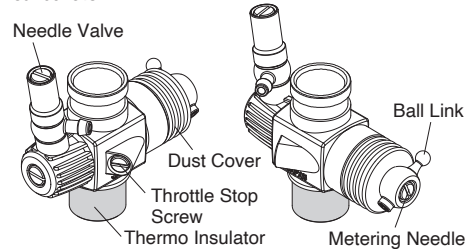

- **The Needle-Valve:**
For adjusting air/fuel ratio (air-fuel mixture) at maximum rpm (fully opened throttle).

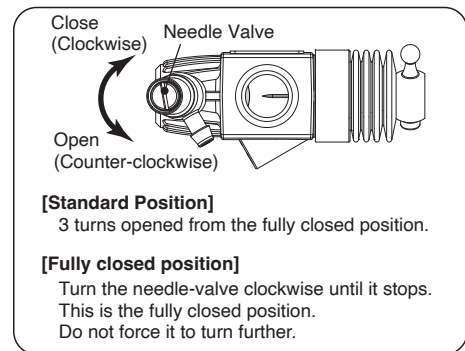

- **The Mixture Control Valve:**
For adjusting acceleration feeling. (Adjusting range should be within ±1 turn.)

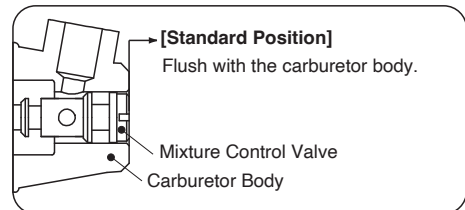

- **The Metering Needle:**
For adjusting idle and acceleration feeling.

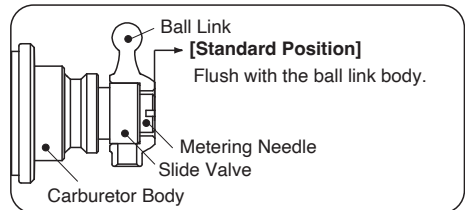

- **The Throttle Stop Screw:**
For setting the minimum idle speed:

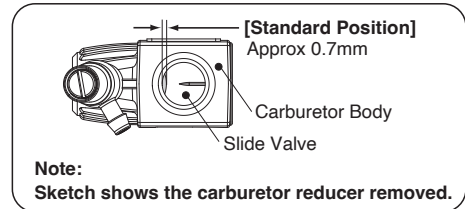

NOTE: While the Mixture Control Valve and the Metering Valve are set at the standard position when the engine leaves the factory, readjustment may be necessary, occasionally to allow for changes in fuel formula and climatic conditions. Readjust the controls only when satisfactory results cannot be obtained with the standard positions following the instructions mentioned in the "CARBURETOR ADJUSTMENT" section.

■ INSTALLATION OF THE CARBURETOR

As delivered, the engine has its carburetor lightly installed in the intake boss. Secure it as follows.

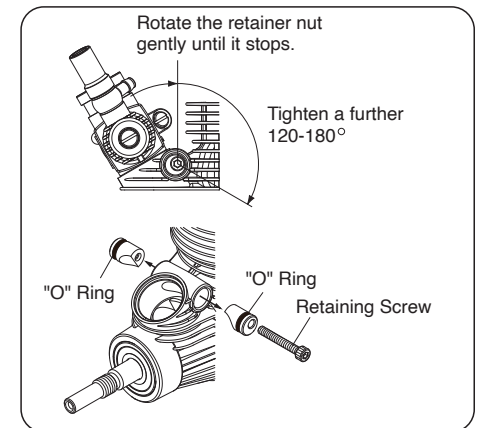

1. Loosen the retainer screw, rotate the carburetor to its correct position and make sure that it is pressed well down into the intake boss, compressing the rubber gasket, before retightening screw.
2. Rotate the retainer screw gently until it stops, then tighten a further 120-180°. Do not overtighten the screw as this will damage the thermo insulator.

Note
Be careful not to damage the "O" rings when removing the carburetor retainer from the engine. First, remove the retainer Retaining screw, then pull out each part. Do not push the part in or damage the "O" rings.

- One of carburetor reducers (6mm or 7mm), which are included as standard accessories must be set in the carburetor. You cannot adjust the carburetor properly without it.

■ ENGINE INSTALLATION

Make sure that the vehicle's engine mounting surfaces are level and in the same plane. Poor installation may cause distortion of the crankcase, bearings, etc., resulting in erratic running and loss of performance. The recommended screws for securing the engine are 3mm or 4-40 steel Allen hexagon socket type. If existing holes in the engine mount do not align perfectly with engine mounting lugs, enlarge them slightly with a needle-file so that screws are in alignment with the mounting holes.

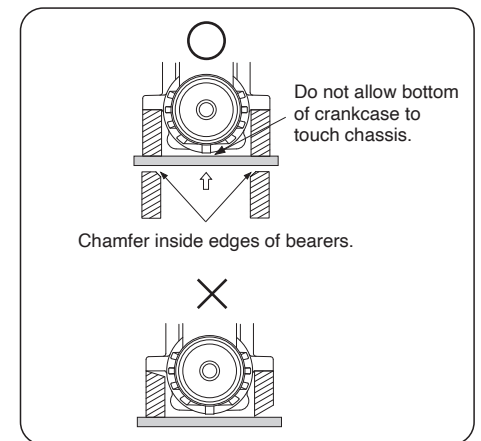

NOTE
The engine bottom may interfere with chassis of some models. In this case, file off the chassis so that the engine may not interfere with the chassis when it is installed.

■ INSTALLING THE MANIFOLD AND SILENCER TO THE ENGINE
Install Exhaust Seal Ring to the silencer. Secure the manifold and silencer with Silencer Joint Springs. After that, fit the manifold into the exhaust of the engine and secure with the Exhaust Header Pipe Springs.

■ STARTING THE ENGINE & RUNNING-IN ('Breaking-in')

Running-in is a procedure for an engine to come close to actual running conditions (fuel, r.p.m., engine temperature, etc.).

Excessively rich running and prolonged low speed running should be avoided. Prolonged low speed running and low temperature running may result in the oil in the fuel becoming gelled and the piston/liner becoming stuck together.

PRESSURIZED FUEL SYSTEM

- It is recommended that a muffler pressurized fuel feed system be used so that the fuel may be stably fed to the carburetor.

The following procedure is suitable when a fuel containing 30% nitro-methane is used.

1. Set the carburetor controls at the standard positions (positions when the engine leaves the factory.)
2. Switch the transmitter and make sure that each linkage moves correctly.
3. Make sure rotating direction of the starter box is correct (counter-clockwise seen from the front edge of the crankshaft), and turn the engine with the starter box to draw fuel into the engine.
4. Connect glowplug battery lead to heat the plug and start the engine with the starter box. When the engine does not start or stops right after being started, try the followings.

- Close the needle-valve approx. 90° from the standard position.
- Set the throttle opening a little wider (approx. 1mm) than the standard setting by adjusting the Throttle Stop Screw.

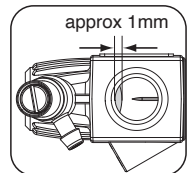

5. When the engine starts, warm it up by repeatedly increasing the rpm to medium speed and back again to a fast idle with the mixture set very rich, glowplug connected, and the driving wheels clear of the ground. The rich mixture will provide adequate lubrication and cooling, indicated by profuse exhaust smoke.

Attention:
It is vitally important to set the throttle at the correct position before starting the engine. If the engine is allowed to run with the throttle too far open under "no load" conditions (i.e. with the driving wheels not in contact with the ground) it will rapidly over-heat and may be seriously damaged.

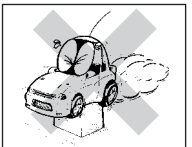

6. When the engine is warmed up, disconnect the glowplug battery and try running the car on the track. If the engine stops soon after running at around mid speed, the mixture is too rich. Close the needle-valve 15-30°. If the engine still stalls, close the metering needle 15-30°. Run the car on the track until one tank of fuel has been consumed, then close the needle-valve very little (within 10°).

7. Repeat this procedure (close needle-valve very little after one tank of fuel has been consumed) until approx. 2 liters of fuel have been consumed, extending gradually the full throttle running time at the straight. Carefully observe the exhaust smoke. Be sure to run the engine with visible white smoke at all times. If the smoke is not visible, the needle-valve is closed too far.

Now the RUNNING-IN (Breaking-in) is completed.

Note:
In the event of any major working parts (e.g. piston/cylinder liner assembly) being replaced or the fuel being changed, especially to high nitro fuel, the complete running-in should be repeated.

ENGINE CONSTRUCTION

With this engine, the piston will feel tight at the top of its stroke (TDC) when the engine is cold. This is normal. The cylinder bore has a slight taper. The piston and cylinder are designed to achieve a perfect running clearance when they reach operating temperature.

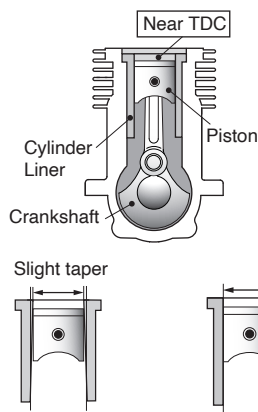

When the engine is cold. When the engine is hot.

■ NOTES ON OPERATION

GUARANTEE

This engine is constructed from the very best materials available and to the very highest engineering standards, using the most advanced precision machinery. However, the extremely high stresses imposed by car racing operation under very severe conditions, as well as stresses which are exacerbated by the use of powerful fuels containing very high concentrations of nitromethane, constitute hazards which are beyond a manufacturer's control. Accordingly, we regret that it is not possible to extend our usual warranty terms to this particular engine - i.e. no guarantee is offered against material wear, or damage resulting therefrom, in actual use.

While Operating

- Please do not run on a public street, this could cause serious accidents, personal injuries and/or property damage.
- Please do not run near pedestrians or small children.
- Please do not run in small or confined areas.
- Please do not run where loud noises can disturb others, such as hospitals and residential areas.

NOTE

As delivered, the engine has the carburetor lightly fit into its intake. Secure it changing its angle according to the car chassis.

■ ABOUT THE ENGINE

MAX-21XR-B Ver.III is designed for 1/8 off-road and 1/8GT car categories. An inner head is redesigned with a new shape, a crankshaft counterweight and port timing is also refined for fast throttle response. A piston and a connecting rod in this engine are the same as we use in OS SPEED series, top quality. Two carburetor restrictors are enclosed as standard accessories. The Orange one (6mm) is for quicker throttle response and the yellow one (7mm) can make the engine more powerful.

Standard accessories

- T Series Plug P3 (Turbo head) 1pc.
- Carburetor Reducer (Orange) ∅6 1pc. (w/ "O" Ring)
- Carburetor Reducer (Yellow) ∅7 1pc. (w/ "O" Ring)
- Exhaust Seal Ring 1pc.
- Instruction Manual

BUGGY COMBO SET(With the above accessories)

- TB02 EFRA2089 (T-2090SC) Tuned Silencer
 - Joint Spring (3pcs.)
 - Exhaust Seal Ring (1pc.)
- MB01-75 (M2000SC) Exhaust Header Pipe
 - Exhaust Header Pipe Spring 102mm (2pcs.)
 - Exhaust Seal Ring (1pc.)

GT COMBO SET(With the above accessories)

- TB01 EFRA2042 (T-2060SC WN) Tuned Silencer
 - Joint Spring (3pcs.)
 - Exhaust Seal Ring (1pc.)
- MB01-70 (M2003SC) Exhaust Header Pipe
 - Exhaust Header Pipe Spring 102mm (2pcs.)
 - Exhaust Seal Ring (1pc.)

■ TOOLS, ACCESSORIES, etc.

The following items are necessary for operating the engine.

● Items necessary for starting

FUEL

Generally, it is suggested that the user selects a fuel that is commercially available for model two-stroke engines. When the brand of fuel is changed, or the nitro content increased, it is advisable to repeat the running-in procedure referred to in the RUNNING-IN paragraphs. Please note that with high-nitro fuels, although power may be increased for competition purposes, glowplug elements do not last as long and engine life will be shortened.

FUEL FILTER

To installed in the fuel line between fuel tank and carburetor to prevent foreign matter from entering the carburetor.

GLOWPLUG IGNITER

Commercially available handy glowplug heater in which the glowplug battery and battery leads are integrated.

STARTER BOX For starting the engine.

FUEL PUMP

For filling the fuel tank, a simple, polyethylene "squeeze" bottle, with a suitable spout, is required.

O.S. SPEED SILICONE FUEL LINE (optional extra)
The connection between the fuel tank and the engine. 2.5mm ID

O.S. SPEED TOOLS (optional extra)

NOTES WHEN APPLYING AN ELECTRIC STARTER

Do not over-prime. This could cause a hydraulic lock and damage the engine on application of the electric starter. If over-primed, remove glowplug, close needle-valve and apply starter to pump out surplus fuel. Cover the head with a rag to prevent any pumped out fuel from getting into your eyes.

